

DP-1510P Features

Digital PPC

- Auto Magnification Selection (with ADF option)
- Auto Paper Selection (with ADF option)
- Job Memory (2)
- Interrupt Mode
- Image Rotation (90 degrees)
- Skyshot Mode
- Margin Mode
- Book Mode
- 2 Page Copy Mode
- 2 in 1 *1
- Edge Erase Mode

Panasonic Document Management System*2

- Document Manager
- Document Scanner
- Document Viewer with Annotation function
- Configuration Editor
- Status Monitor

Printer

- Collation Stack
- N in 1 (2 in 1, 4 in 1)
- Network Printing *3
- Rotate Sort *4
- Image Overlay (Only for Windows® 98/Me)*4

Others

- Self Diagnostic Function
- Power Save Modes
- Department Counter (50 departments)

Control Panel



Options

You can select a number of options that make the WORKiO DP-1510P a useful and versatile work centre.

Function Enhancing Options

10/100 Ethernet Interface Kit	DA-NE200
PCL6 Emulation Kit	DA-PC210
Image Memory for Electronic Sort	DA-SM08B (8MB)
	DA-SM16B (16MB)
	DA-SM64B (64MB)*7
	DA-SM28B (128MB)*7
Key Counter Cable Kit	DA-KH200
Toner Bottle	DQ-TU10C

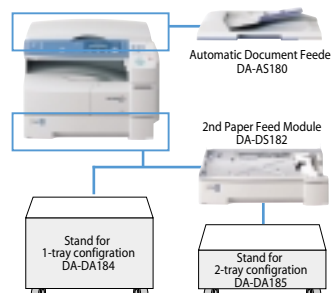

Dimensions

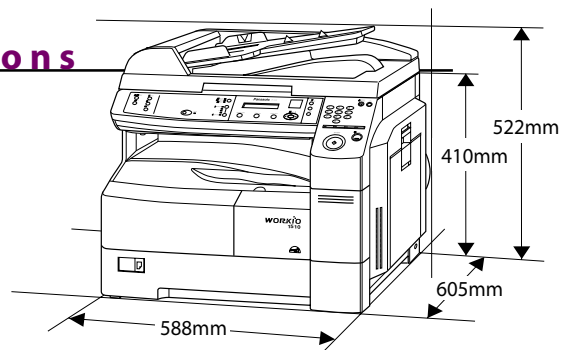

DP-1510P Specification

Basic / Digital PPC

Type	Desktop
Copy / Print Process	Laser Electrostatic photographic method
Developing Process	Dry type single component imaging
Warm - up Time	Approx. 30 sec.
First Copy Time	6.5 sec. (A4)
Resolution	600 dpi
Gray Scale	256 steps
Multi Copy Speed	15 cpm (A4)
Maximum Original Size	A3
Copy Size	A3, B4 Foolscap (8.5" x 13", 8" x 13"), A4, A5
Copy Ratio	Enlargement (fixed) 200%, 173%, 146%, 141%, 137%, 122%, 115%, 103% Reduction (fixed) 97%, 90%, 87%, 82%, 73%, 71%, 68%, 64%, 58%, 50%
Zoom (variable)	50~200%
Automatic Document Feeder (Option)	50 sheets (A4) / 30 sheets (A3, B4)
Paper Feed	550-sheet paper tray x 1 + 50-sheet bypass Max.: 1,150 sheets with optional paper tray x 1
Multiple Copy	999
Exposure Controller	Photo, Text / Photo, Text
Page Memory Capacity	16MB
Sort Memory Capacity	8MB*6
Optional Memory	Base Memory plus 8MB / 16MB / 64MB*7 / 128MB*7
Power Requirement	AC220-240V 50/60 Hz Single phase
Power Consumption	Max: Less than 1.2 kW Energy Saver mode: Approx. 38 Wh Sleep mode: Approx. 2.2 Wh
Dimensions (W x D x H)*5	588 x 605 x 410 mm H: To Platen Glass
Weight*5	41 kg (Excluding optional equipment)

Printer / Scanner

Printer Interface	Bi-directional Parallel (IEEE1284) Network (Ethernet 10Base-T/100Base-TX) with optional 10/100 Ethernet Interface Kit
Printing Speed	15 ppm (A4)
Printing Resolution	600 dpi
Scanning Resolution	600 dpi
Scanner Driver	TWAIN
OS	Windows® 98 / Me / XP / 2000, Windows NT® 4.0
Page Description Language	PCL6 Emulation (with optional PCL6 Emulation Kit)

Notes

- *1 Optional ADF is required.
- *2 Local connection only.
- *3 Optional 10/100 Ethernet Interface Kit is required.
- *4 Optional PCL6 Emulation Kit is required.
- *5 Dimensions and weight are approximate.
- *6 Sort memory for sorting print from PC. (Printer Function)
- *7 Image Memory for Electric Sort (DA-SM64B, DA-SM28B) options may not be available in certain countries.

Microsoft®, Windows® and Windows NT® are registered trademarks of Microsoft Corporation. PCL6 is a registered trademark of Hewlett-Packard. WORKiO is a registered trademark of Matsushita Graphic Communication Systems, Inc. All product names are trademarks of their respective holders.

Design and specifications are subject to change without notice.

ISO 9001 Quality Management System

Every aspect of Matsushita Graphic Communication Systems, Inc. (MGCS) office information equipment business processes, from manufacturing to marketing, conforms to ISO (International Organisation for Standardisation) 9001 quality management system standard.

Design, development, manufacture, installation, repair and maintenance of office information equipment, their associated devices and consumables.



In addition, MGCS's plants outside Japan have acquired ISO 9002 certification.

WORKiO™

DIGITAL IMAGING SYSTEMS

Panasonic

DP-1510P

Copier

Printer

Scanner

- 15 cpm / 15 ppm digital copier/printer
- A3 size scanner / printer
- Network printer capability
- Compact body and easy to use interface

Panasonic®

Panasonic and National are the brand names of Matsushita Electric.

Matsushita Electric Industrial Co., Ltd.

Matsushita Graphic Communication Systems, Inc.

MG-C407EE 0203 Printed in Japan



Paper to digital, input to output...
document handling has never been
this easy and efficient.

The WORKiO line of digital imaging systems is dedicated to making information handling as easy as possible. Whether you are copying, printing from your PC, e-mailing as an attached file or simply storing documents as digital files for easy retrieval later, WORKiO does it all. Panasonic's expertise in designing and engineering reliable and user-friendly office equipment has gone into the creation of the new WORKiO DP-1510P. It's the ideal multi-function copier/printer just right for small workgroups and growing businesses.



The compact, versatile solution to all the needs of a small to medium office or work group.

You know you need a copier with a printer and scanner that can be networked with your PC's. However, space is limited.

THE WORKiO SOLUTION – 1

Space-saving design with multi-function convenience.

The WORKiO DP-1510P combines a copier, scanner and network printer functions in a compact unit. It copies and prints on paper as large as A3 size, yet it's small enough to fit in a corner because the inner paper tray output design means no extra protruding paper trays.

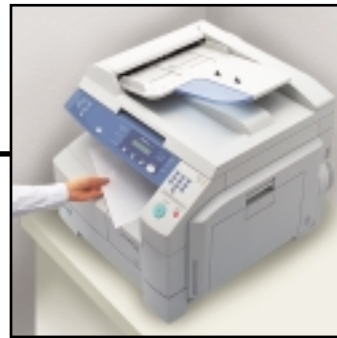

Your paper and digital documents are stored everywhere and anywhere! You need to organise your document workflow.

THE WORKiO SOLUTION – 2

Handle input and output in one place.

Organising all of your work, both paper and digital, is easy with the WORKiO DP-1510P. The scanner function makes all your document data instantly accessible from your PC. The Document Management software allows you to easily save, edit, search and share the stored documents with everyone in your work group.

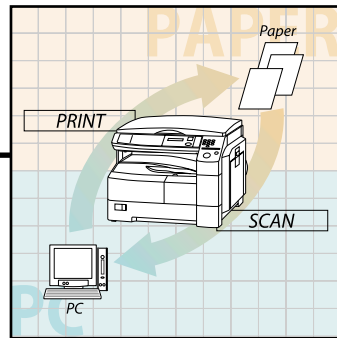

You want a machine that meets your needs without being complicated – a machine that everyone finds easy to use.

THE WORKiO SOLUTION – 3

A well designed front panel with only the features you need.

The WORKiO DP-1510P offers the features a growing business needs, without excess complexity. Following Universal Design principles for ease of use and accessibility, its control panel is set low and angled for convenient operation. The clean layout has buttons that are easy to see and operate.



Versatile Document Management System

The WORKiO DP-1510P comes supplied with Document Management software that gives you efficient, versatile control over your documents. Installed in your PC, it makes your scanned-in data easy to manage, edit and even share on network PCs. Images can be manipulated in many ways, including superimposing text and graphics. It's a snap to send documents via e-mail – just attach them directly to e-mail messages with a simple drag-and-drop operation.

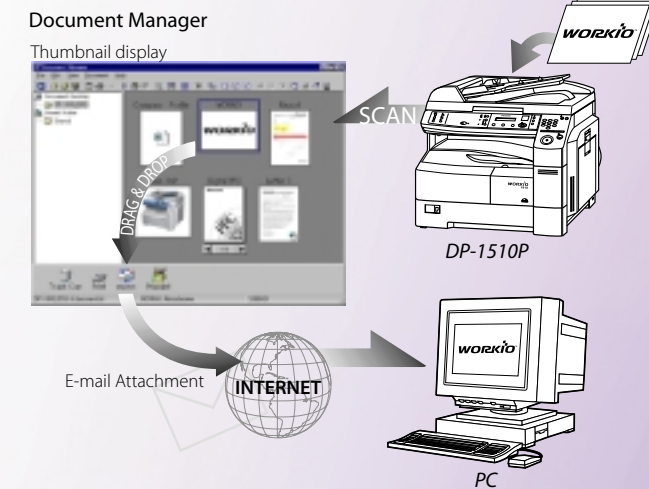

Networkable A3-Size Laser Printer

Connected to your PC, the WORKiO DP-1510P becomes a high-speed 15 ppm laser printer with 600 x 600 dpi resolution. Unlike most PC printers, it can handle paper sizes as large as A3. Its Ethernet 10/100BaseTX interface makes it ready for use as an office network printer, and a fast network printer with the optional PCL6 Emulation Kit.

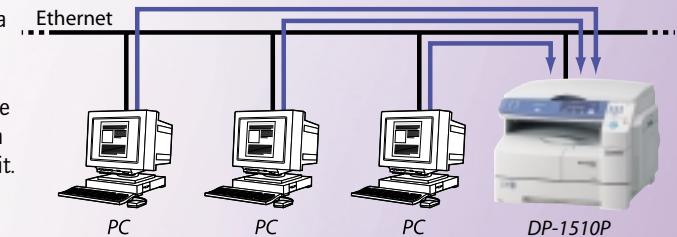

High-Speed Digital Copier

As a digital copier, this versatile machine delivers a brisk 15 pages per minute up to A3 size. You'll also appreciate its many efficient features. 2-in-1 copying reduces paper usage by fitting two reduced images on one sheet. Digital Skyshot lets you copy small-size originals without annoying black borders. And Image Rotation gives you accurate copies regardless of the original's orientation.

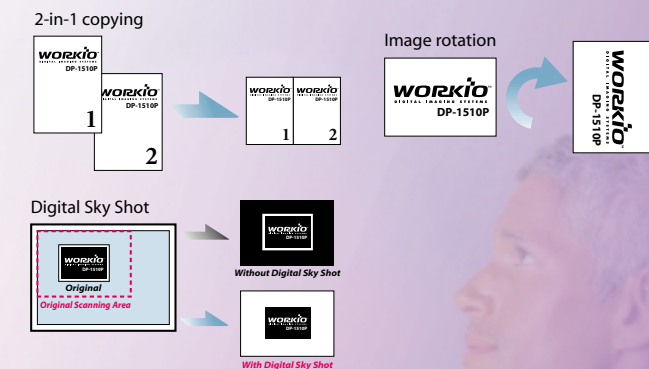

Energy-Saving Design

The WORKiO DP-1510P has a number of features designed to conserve energy and keep operating costs to a minimum. The Energy Saver Mode significantly reduces power consumption when the machine is idle. And when the WORKiO DP-1510P enters Sleep mode, power consumption drops to approx. 2.2 Wh.

As an ENERGY STAR® Partner, Panasonic has determined that this product meets the ENERGY STAR® guidelines for energy efficiency.

